

230_{VAC}

BULL17 OMI



INDUSTRIAL USE

control unit with built-in inverter and virtual encoder
oil lubricated reductions
personalised release key

**up to 1700 kg****BENINCA**

100%
Made in Italy

230 Vac

- Single phase 230 VAC geared motor for intensive use with oil lubricated reductions
- The main control unit, located in the top part of the motor and with integrated inverter, makes it possible to calculate the position of the motor starting from the measurement of current intensity on the electric motor (virtual encoder)
- Oil lubrication guarantees maximum duration of the reducer. The type of oil is very effective and guarantees excellent performance even at low temperatures
- Reduced mechanical wear of components
- The virtual encoder allows proper management of the slowing-down phases, movement tracking (STC system), and torque management in relation to the position of the gate, which guarantees maximum safety
- Adjustable speed from 10 to 24 m/min according to gate weight
- Safety sensor that stops the motor power supply during release operations
- Receiver ONE2.WI is supplied
- Metal release lever



CONTROL UNITS:

BULL17 OMI ——— CP.BULL OMI

Foundation plate with anchor bolts included.
Motor and floor fixing distance
269 mm x 106 mm, no. 4 Ø 12 mm.

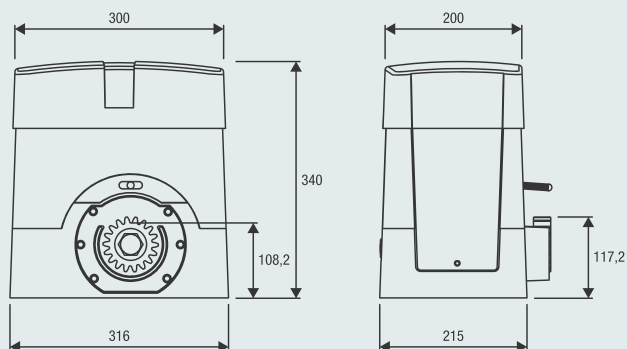

Weight (kg)	Speed (m/min)
1,700	17
1,000	20
500	24

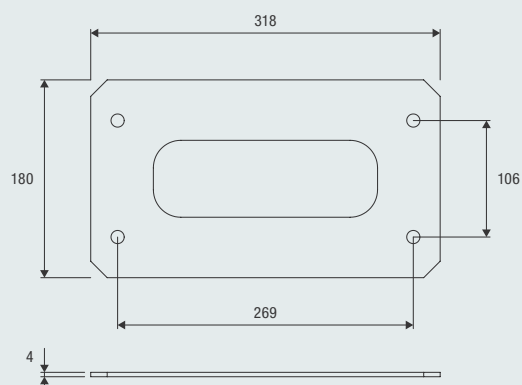



RI.M4F

M4 rack, to weld or attach with screws, 30x12x1000 mm slotted and galvanised. Supplied with M6 metric screws and threaded spacers. **Package of 4 pcs.**



RI.M4Z

M4 galvanised rack to weld 22x22x2000 mm. **Package of 2 pcs.**



RI.M4ZF

Galvanised slotted M4 rack 22x22x2010 mm for fastening to the side with the teeth. Supplied with M6 screws. **Package of 1 pc.**

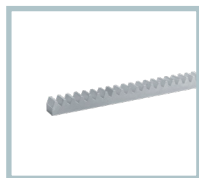

RI.M6Z

M6 galvanised rack to weld 30x30x2000 mm. Requires pinion RI.P6.



RI.P6

M6 gear, it needs the rack RI.M6Z.



BULL.PI

Raised foundation plate. Height 32 mm. Floor fixing distance 280x170 mm, no. 4 Ø 11 mm, motor fixing distance 269x106 mm n.4 M10.



SB.BULL20.F

Externally fitted anti-intrusion cable unlock device (L=4.5m).



RF.SUN

Battery-operated device recharged by means of a photovoltaic panel applied on a mobile edge.



RF

Device with a non-rechargeable battery, with guaranteed duration 2 years.



SC.RF

Device powered at 12/24 Vdc with self-test function and 2 outputs for connection to the electronic control units.



ID.TA

Warning board.



IRI.TX4VA

4-channel transmitter with Advanced Rolling Code and Rolling Code.



IRI.TX4AK

4-channel transmitter with Advanced Rolling Code and Fixed Code.



IRI.LAMP

White full range flashing light, 20-255 VAC with built-in aerial.



IRI.KPAD

Battery operated wireless vandal-proof digital keypad with alert buzzer and backlit buttons. Triple coding: Rolling Code, Programmable Code and Advanced Rolling Code. 254 memorisable codes.



IRI.CELL

Pair of vandal-proof metal covers for PUPILLA/PUPILLA.R photocells, comprising front and rear shells with concealed screw. They can maintain perfect orientation over 180°.



PUPILLA

Pair of photocells adjustable to 180°. Option to synchronise up to 4 pairs, 24 VAC/DC power supply. Easy adjustment through a LED that signals optimal alignment. Compact size: 36x110x35 mm



DA.2S

Electronic board that allows synchronised movement of 2 automation devices (opposed sliding gates).

AUTOMATISMI BENINCÀ SpA • Via del Capitello, 45 • 36066 Sandrigo (VI) ITALY • T +39 0444 751030 • sales@beninca.com

TECHNICAL DATA	BULL17 OMI*
Power supply	230 Vac (50-60Hz)
Motor supply	230 Vac
Max absorbed current	7 A
Max Thrust	1880 N
Max opening speed	24 m/min
Duty cycle	80%**
Protection level	IP44
Magnetic limit switches	NO
Operating temperature	-20°C /+50°C
Lubrication	OIL
Max gate weight	1700 kg
Driving gear for rack	M4 Z18
Weight	21.6 kg
Items no. per pallet	20

* Available in 115 VAC version | ** In extreme operating conditions (environment T 50°C, speed 24 m/min, gate weight 500 kg) the cycle falls to 40%